

Data Sheet



Article number: 201355120

Description: E+G Klee vertical clamp
GN 820.1-355-N forked clamping arm

Measures

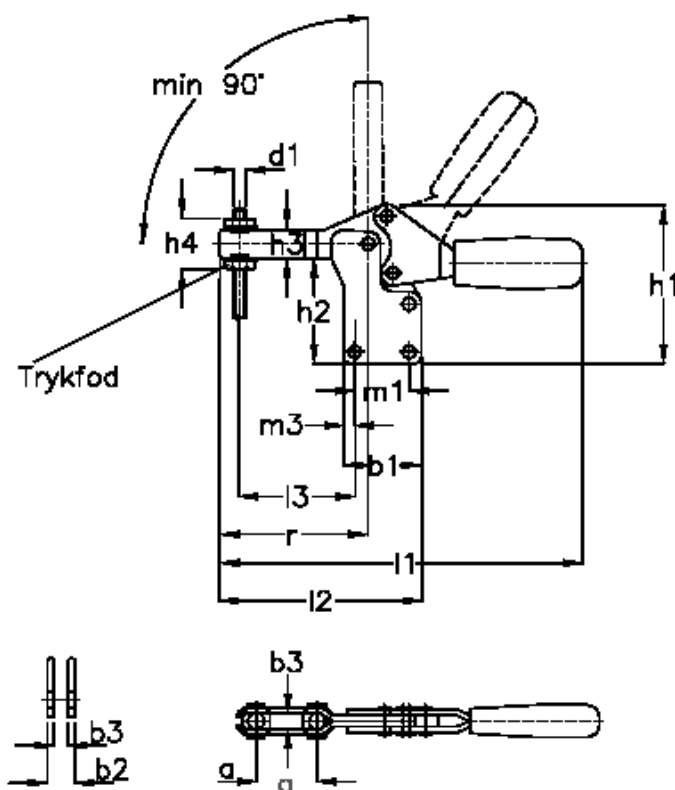

a = 58	h2 = 69.0	m2 = 7.5
b1 = 60	h3 = 22	m3 = 9.5
b2 = 14	h4 = 43	r = 108.5
b3 = 7	Holding force N = 3200	s = 7
b4 = 10.4	l1 = 270	Size = 300
d1 = M10	l2 = 160	
d2 = 8.5	l3 = 96.0	
h1 = 102.0	m1 = 41.0	